



## GNSD

Genie MR16 Fully Recessed Emergency Light

DATE:

PROJECT

COMMENTS:

### FEATURES

- Fully self-contained emergency light that can be recessed into walls or ceilings.
- Virtually invisible during normal lighting conditions.
- Four selectable lamp positions for each lamp ensures optimum light distribution.
- Can be field painted or wall-papered to seamlessly blend with architecture.
- UL listed for 90 minutes of emergency run time.
- Advanced microprocessor self-diagnostics are standard on all units.
- Universal backbox can be pre-shipped for pre-installation at job-site.
- Discreet, automatic monthly self-diagnostics monitors lamp load transfer circuit, battery capacity, door operation, and motor drive to ensure proper functioning during an emergency.
- Optional infra-red remote transmitter has selectable 30 second or 90 minute tests.
- No gears, cogs, limit switches, or sensitive solenoid setting to jam or fail.
- Self adjusting frame trim and door assembly with construction.
- Textured white powder, coated die-cast zinc frame and door. No external mounting hardware is required.
- Suitable for mounting heights up to 50', depending on lamp wattage selected.
- Reliable, continuous cam, precision DC motor drive is used for smooth extension and retraction.
- Solid state microprocessor controlled circuitry is used for increased reliability.
- Line-latch prevents unnecessary discharge of battery during installation.
- Brownout sensing ensures emergency operation during periods of low line voltage.
- LED indicator and push-to-test button is provided standard in all units for manual testing.
- 120/277 VAC with field selectable inputs.



CLICK THE IMAGE TO VIEW ALTERNATE PRODUCT PHOTOS  
Only available with Adobe Acrobat and Acrobat Reader

### ORDERING INFORMATION *GNSD-LC-20LC2H-MR*

#### 1. SERIES

GNSD

#### 2. OPERATION

20LC2H 2 Hour Lead Calcium Battery 20 Watt MR-16 Lamps  
 35LC2H 2 Hour Lead Calcium Battery 35 Watt MR-16 Lamps  
 50LC2H 2 Hour Lead Calcium Battery 50 Watt MR-16 Lamps  
 12LC3H 3 Hour Lead Calcium Battery 12 Watt MR-16 Lamps  
 35LC3H 3 Hour Lead Calcium Battery 35 Watt MR-16 Lamps  
 12LC4H 4 Hour Lead Calcium Battery 12 Watt MR-16 Lamps  
 20LC4H 4 Hour Lead Calcium Battery 20 Watt MR-16 Lamps  
 50LC90 90 Minute Lead Calcium Battery 50 Watt MR-16 Lamps  
 75LC90 90 Minute Lead Calcium Battery 75 Watt MR-16 Lamps

50NC2H 2 Hour Ni-Cad Battery 50 Watt MR-16 Lamps  
 20NC2H 2 Hour NiCad Battery 20 Watt MR-16 Lamps  
 35NC2H 2 Hour NiCad Battery 35 Watt MR-16 Lamps  
 12NC3H 3 Hour NiCad Battery 12 Watt MR-16 Lamps  
 35NC3H 3 Hour NiCad Battery 35 Watt MR-16 Lamps  
 12NC4H 4 Hour NiCad Battery 12 Watt MR-16 Lamps  
 20NC4H 4 Hour NiCad Battery 20 Watt MR-16 Lamps  
 50NC90 90 Minute NiCad Battery 50 Watt MR-16 Lamps  
 75NC90 90 Minute NiCad Battery 75 Watt MR-16 Lamps

#### 3. MOUNTING

MRLB Recessed / PRESHIP Back Box (Must order GNSD-ACCY-RBB)  
 MR Recessed / Ship complete

#### 4. OPTIONS

BLANK = NO OPTION  
 CP Chicago Plenum Listed  
 LD Damp Location  
 RL Fused Remote Output Leads

RT Remote Diagnostic Status Display Panel  
 TD Time Delay - 120/277 VAC (15 min)  
 CC Custom Color

### ACCESSORIES; ORDER SEPARATELY

- **GNSD-ACCY-RBB** = Pre-ship backbox for GNSD
- **TLRT** = Infrared Remote Control

**SPECIFICATIONS**
**CONSTRUCTION**

- Textured white powder coated, die-cast zinc frame and door

**OVERALL SIZE**

- Front Panel: 14.4375" x 7.625"

**ROUGH-IN SIZE**

- 13.5" x 6.75"

**TEMPERATURE RATING**

- LC: From 45°F to 85°F
- NC: From 32°F to 102°F

**APPROVALS**

- UL 924
- NY City approved calendar #48850
- NFPA 101 Life Safety Code
- NFPA 70-NEC
- OSHA

**WARRANTY**

- Isolite offers a 5-year limited warranty. For further details, refer to General Warranty and Obligations in the Isolite manual or on our website. Lamps not warranted.

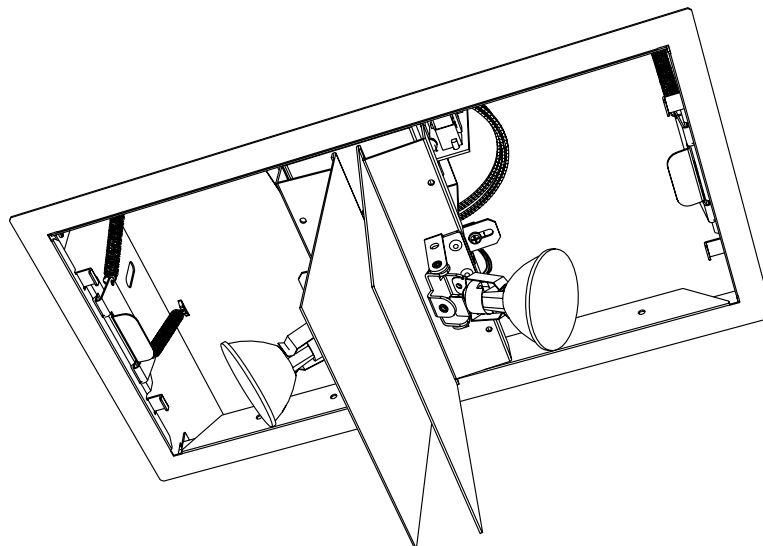
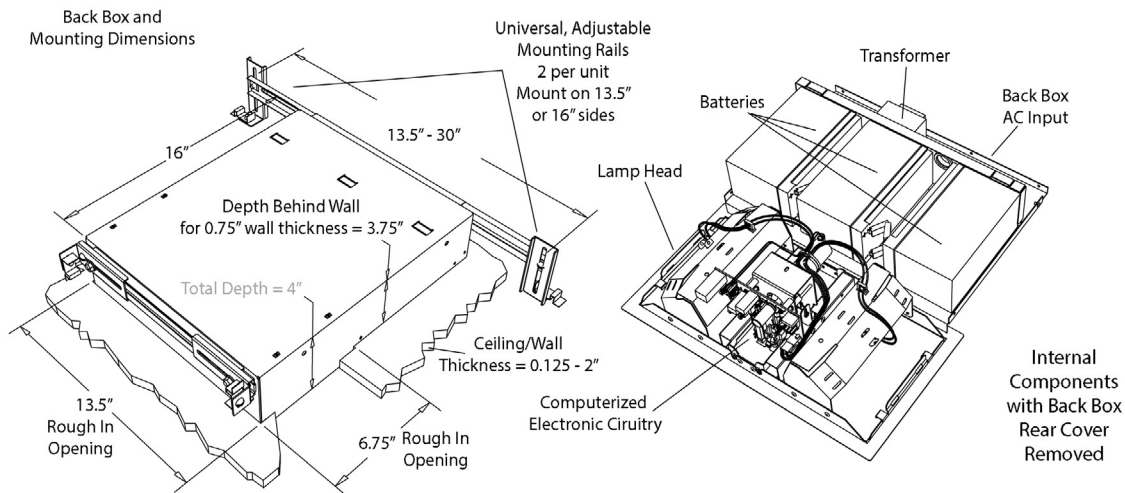
**DIMENSIONS**

Adjustable Lamp Holder