

TWO CIRCUIT INPUT OPTION (AC VERSIONS ONLY)

For AC versions with two circuit input, connect the input power from the main input to the leads marked MAIN, and from the backup input to the leads marked BACKUP. Note that the main and backup voltages can be either 120V or 277V. They do not have to be the same voltage. Connect to the Black lead for 120V or Orange lead for 277V, and White lead for Neutral. Cap off the unused leads.

FLASHER / FIRE ALARM / BUZZER OPTIONS

Battery Backup Emergency signs that are equipped with the FLASH IN EMERGENCY MODE OPTION or BUZZER IN EMERGENCY MODE option will automatically flash/beep in the emergency mode but not flash/beep on AC operation. AC Only exit signs that are equipped with the flash or buzzer options will flash/beep continuously while power is supplied.

AC Only and Battery Backup Emergency signs that are equipped with the FIRE ALARM SIGNAL MODE FLASH or BUZZER options will automatically flash/beep in both AC and emergency modes upon application of a fire alarm signal to the YELLOW 18 AWG leads. The fire alarm signal can be either AC or DC of either polarity, and range from 12 to 24 volts. The current draw from the fire alarm signal is less than 10 milliamps.

Units that include one of the above options, are intended for installation in locations where such features are permitted by local codes.

Flasher Rate: 60 per minute

Duty Cycle: 50 percent

DIAGNOSTICS

For units with Self-Testing / Self-Diagnostics option, refer to additional Operating Instructions. Battery back-up units without Self-Testing / Self-Diagnostics option include a battery diagnostics system which indicates, via flashing of the indicator light, that the battery needs replacement. If flashing occurs after a new installation, check that the battery plug is properly inserted into the circuit board connector.

TEST FOR BATTERY BACKUP WITHOUT SELF-TEST / SELF-DIAGNOSTICS

To test Battery backup units, use test switch to simulate AC power outage. The indicator light will go out, and the sign will remain lit, indicating transfer to emergency mode, and remain lit on battery power until switch is released. Release of switch will automatically restore AC/battery charge mode, with indicator light on. Testing for longer periods is best accomplished by turning off AC circuit power. Signs should be tested in accordance with National Electric Code and NFPA 101 Life Safety Code requirements which specify monthly testing for 30 seconds and yearly testing for 90 minutes. Note that the batteries will take some time to reach full charge after a prolonged test, and that the unit cannot provide full duration operation should a real power outage occur before the batteries have had an opportunity to reach full charge. It is recommended that long duration tests be limited to once yearly, and be conducted when the area will be unoccupied afterwards.

BATTERY REPLACEMENT

To replace battery, disconnect branch circuit, detach unit from junction box, and cut plastic strap securing battery inside power supply chassis. Unplug battery connector from Printed Circuit assembly. Replace battery only with part number B310013.

This product contains Ni-Cd batteries. Used Ni-Cd batteries may not be disposed of in the municipal solid waste stream. Ni-Cd batteries must be recycled or disposed of properly. For information on local recycling drop-off points, phone toll free 1-800-BATTERY.

Z410041

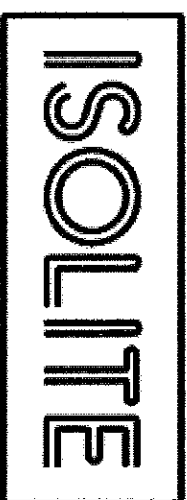

THINLINE - TL SERIES DIE CAST ALUMINUM LED EXIT SIGNS

INSTALLATION AND OPERATING INSTRUCTIONS

IMPORTANT SAFEGUARDS

When using electrical equipment, basic safety precautions should always be followed including the following:

READ AND FOLLOW ALL SAFETY INSTRUCTIONS

1. Do not use outdoors.
2. Do not mount near gas or electric heaters.
3. Equipment should be mounted in locations and at heights where it will not readily be subject to tampering by unauthorized personnel.
4. The use of accessory equipment not recommended by the manufacturer may cause an unsafe condition.
5. Do not use this equipment for other than intended use.
6. Supply connections must be made either inside the junction box for surface mount or the splice box in the recessed mount backbox.
7. Install using recommended junction box only.
8. Servicing of this equipment should be performed by qualified service personnel.

SAVE THESE INSTRUCTIONS

31 Waterloo Avenue • Berwin • PA 19312 U-S-A
Telephone: (610) 647-8200 • Fax: (610) 296-8952

DIRECTIONAL INDICATORS

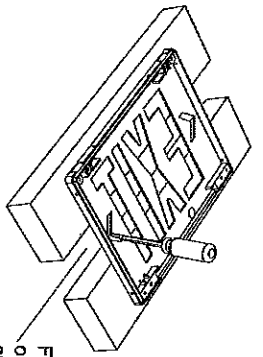

For front, die-cast face, knock out desired directional indicator(s) supporting Faceplate as shown

Determine which directional indicator(s) are to be removed. Knock out as shown in the attached diagram. For the rear face on a double face sign, remove the tape and punch out the indicator(s).

All units, except Remotes, mount to a 4 gang masonry box supplied. Box must be mounted flush with wall surface. Remotes can be mounted to a standard 4" octagon J Box (supplied by others).

INSTALLATION OF REMOTE SIGN

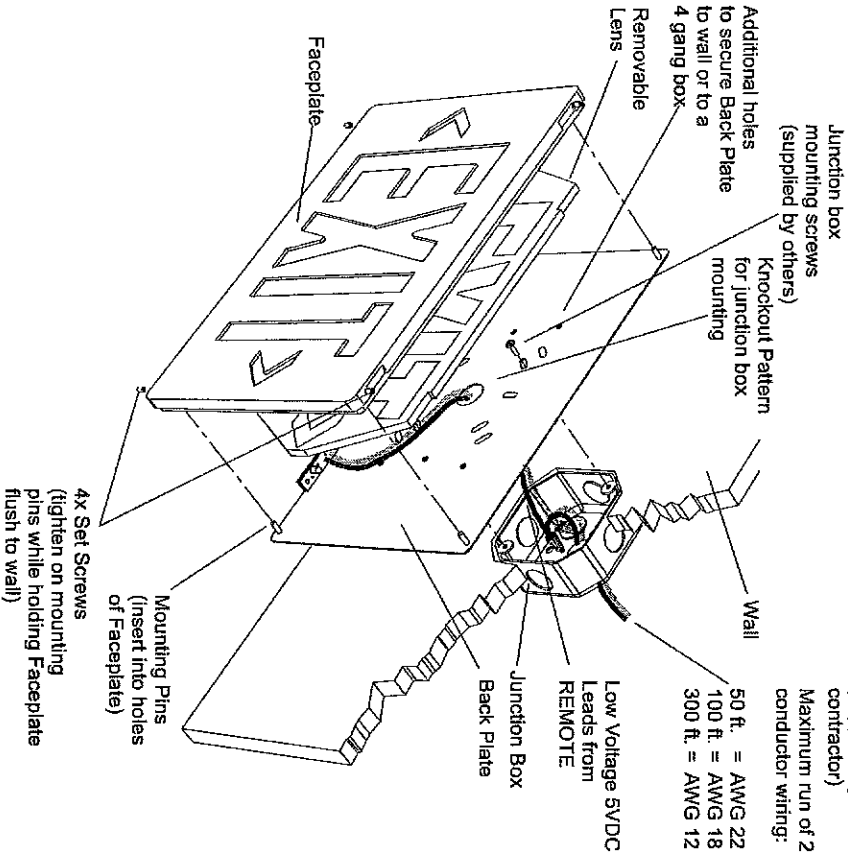

INSTALLATION OF MASTER SIGN

Before installing unit, disconnect power at breaker panel

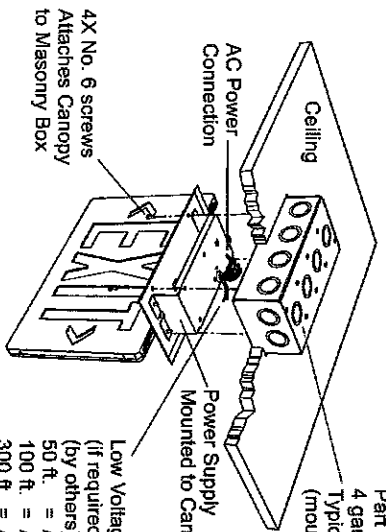

Single or Double Face Sign

TOP OR END CANOPY MOUNT

Low Voltage 5VDC connection to REMOTE SIGN (if required). Maximum run of 2 conductor wiring (by others):
50 ft. = AWG 22
100 ft. = AWG 18
300 ft. = AWG 12

WALL MOUNT

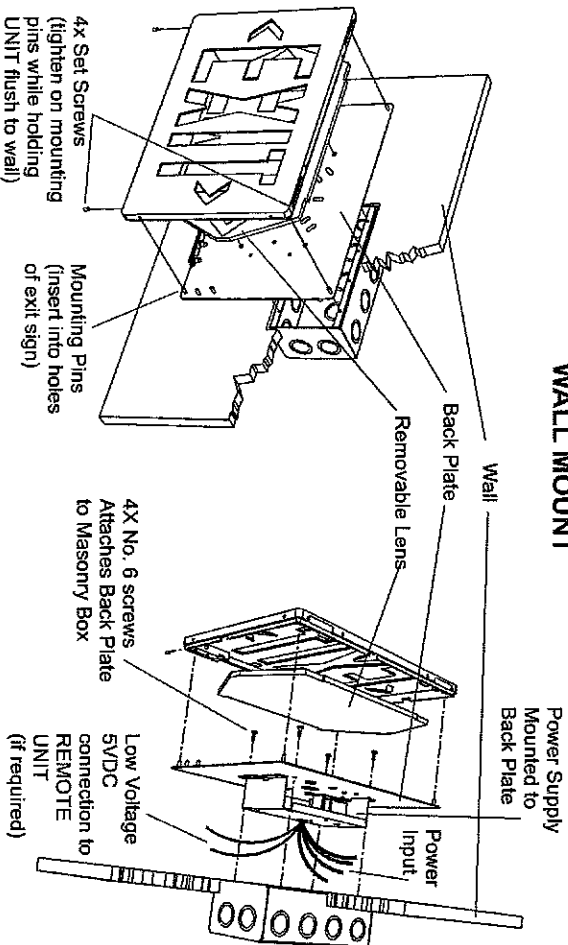

Connect power input wires to feed wires in junction box as per local code
Black lead for 120V or Orange lead for 277V CAP UNUSED LEAD
White lead for neutral
Green/Yellow lead for Ground.

REAPPLY POWER AND NOTIFY THE AUTHORITY HAVING JURISDICTION